

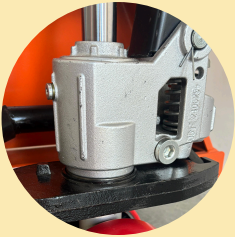

V-TAL[®]

“The quality of expectations determines the quality of our action”



Heavy Casting Pump



PU Red Wheel



Nylon White Wheel



Heavy Metal Wheel



- High reliability and long service life of 5 years.
- Double lifting speed when loads under 600kg, which turns back to regular speed when above it.
- Impact free lifting ensures safety of cargo loading.
- The lifting system is equipped with overloading protection valve to ensure the safe operation.
- The utilized structural design guarantees the convenience of assembling and disassembling.
- Light-weight fork frame, made from high rigidity steel plate.
- Compact appearance, complete rocker arm, ensure the whole truck evenly pressed.
- There is a finger hole in the connection of handle and pump, easy to assemble.

**HEAVY DUTY
HAND PALLET TRUCK**

Features:

- * *Three position control handle - lift, neutral & lower.*
- * *Reliable hydraulic pump.*
- * *Available with nylon and metal wheels rollers.*

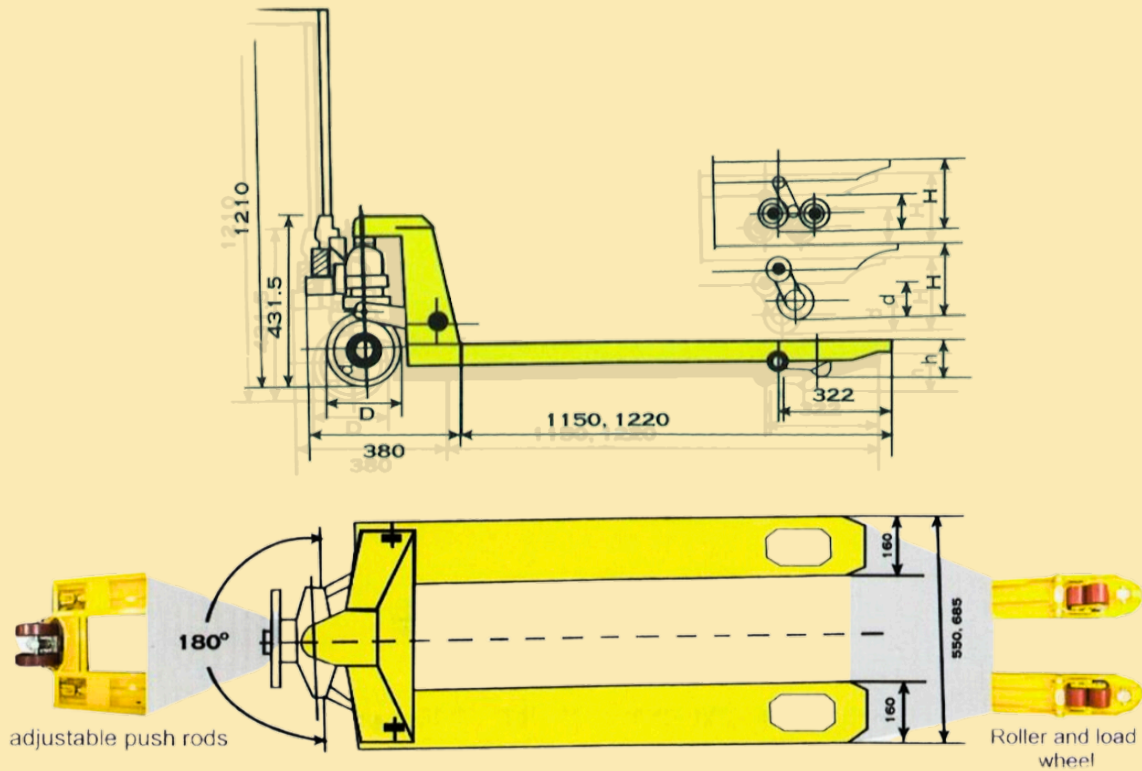

Load wheel (d):80 X 70mm

Max. Lifting height (H) : 200mm

Steering Wheel (D) : 200X50mm

Min. lowering height (h) : 85m

TECHNICAL SPECIFICATIONS

Item/Type		UQ20		UQ25		UQ30		UQ50	
Capacity (kg)		2000		2500		3000		5000	
Min. fork height(mm)		85	75	85	75	85	75	88	78
Max. fork height(mm)		200	190	200	190	200	190	205	195
Steering wheel (mm)		200X50	180X50	200X50	180X50	200X50	180X50	200X180	
Load roller	Single	82X93	74X93	82X93	74X93	82X93	74X93	85X80	
	Tandem	82X70	74X70	82X70	74X70	82X70	74X70	75X80	
Size of fork(mm)		160X50				160X60		180X50	
Width overall forks(mm)		450/520/550/685							
Fork length(mm)		800/900/1000/1067/1100/1150/1220							